



- (q)  $\oint \vec{B} \cdot d\vec{s} = 0$  (ii) Ampere's law
- (r)  $\oint_L \vec{H} \cdot d\vec{l} = \int_s \vec{J} \cdot d\vec{s}$  (iii) Gauss's law
- (s)  $\nabla \cdot \vec{E} = 0$  (iv) Conservativeness of electrostatic field
- (A) (p) (q) (r) (s)  
 (i) (ii) (iii) (iv)
- (B) (i) (ii) (iii) (iii)
- (C) (iii) (i) (ii) (iv)
- (D) (iii) (i) (ii) (iii)

**Q.5–10 carry two marks each**

5. The transformer secondary in star supplies power to a purely resistive load, with one ammeter & wattmeter connected as shown in figure. The readings on the ammeter and voltmeter are 27 A and 648 W respectively. The line to line voltage are balanced. Considering upto third harmonic the value of the resistor R will be

- (A) 2Ω  
 (B) 3Ω  
 (C) 2.98Ω  
 (D) 2.67Ω

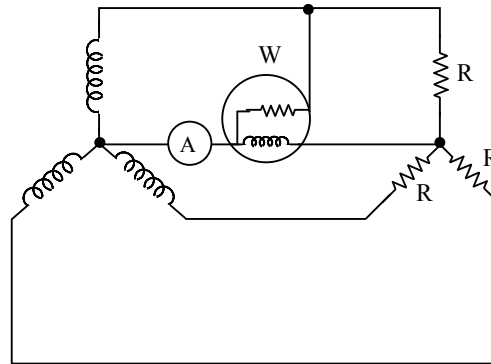

6. A 240V shunt motor has an armature resistance of 0.5 Ω and takes an armature current of 45A on a certain load. Neglecting saturation & armature reaction. The speed is to be raised by 50% the reduction in main flux required if the developed torque is constant will be
- (A) 55% of  $\phi_1$  (B) 58% of  $\phi_1$   
 (C) 60% of  $\phi_1$  (D) 62.5% of  $\phi_1$
7. Following data for a 3-phase IM is given below  
 Max starting current = Full load current  
 Full load slip = 0.016  
 Rotor resistance / phase = 0.016 Ω  
 If a 5 section rotor starter is used for starting purpose, the resistance of 5 sections are
- (A) 0.66, 0.4, 0.3, 0.28, 0.01 Ω  
 (B) 0.76, 0.3, 0.25, 0.11, 0.045 Ω  
 (C) 0.56, 0.25, 0.11, 0.045, 0.019 Ω  
 (D) 0.66, 0.5, 0.4, 0.32, 0.21 Ω
8. Power flowing in 3-φ, 3 wire system is measured by two wattmeters whose reading are 7000 W and –2500 W. If the voltage of the circuit is 400V, then what will be the value of

**Getting into the I.I.T.s is your aim, taking you there is ours.**

capacitance introduced in each phase to make one wattmeter read zero. The frequency is 50 Hz.

- (A) 500  $\mu\text{F}$  (B) 668.6  $\mu\text{F}$   
 (C) 1000  $\mu\text{F}$  (D) 748.5  $\mu\text{F}$

9. A 50MVA, 132/33kV star delta bulk supply transformer protected by Merz price scheme has 1A secondary C.T rating. Then the C.T ratio of primary side will be  
 (A) 1: 378.78 (B) 126.41 :1  
 (C) 218.69: 1 (D) 378.78 : 1

10. Consider the circuit shown below

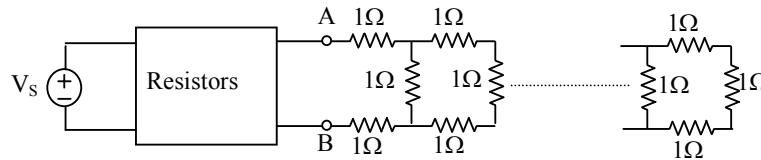

Short circuit current is 2A and open circuit voltage is 5 V. Then voltage across AB under practical implementation is given by \_\_\_\_\_

- (A) 0.741 V (B) 5 V  
 (C) 3 V (D) 2 V

